

1/1.8" F4.5系列长焦镜头 600068

1/1.8" C 400-1100nm

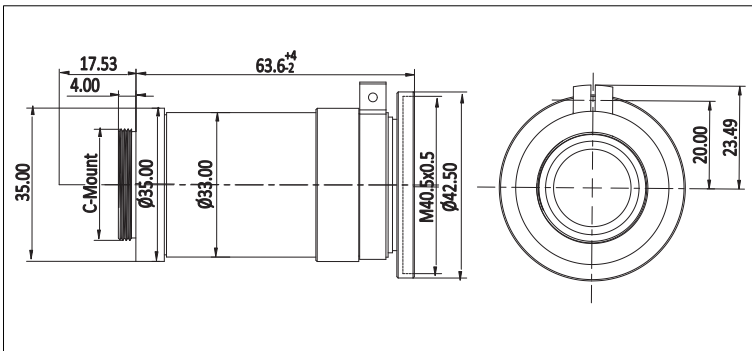

No	项目	规格
1	最大传感器尺寸	1/1.8"(9mm)
2	焦距	105mm
3	接口	C-Mount
4	F/#	F4.5(固定光圈)
5	工作距离	5m~∞
6	视场角(对角×水平×垂直)	1/1.8" 4.89°×3.92°×2.94°
		1/2" 4.35°×3.48°×2.62°
		1/3" 3.27°×2.62°×1.96°
7	对象大小(在最近对焦距离处)	1/1.8" 412.8×330.6×248.1mm
		1/2" 367.1×293.9×220.6mm
		1/3" 275.6×220.6×165.5mm
8	后焦距(in air)	55.4mm
9	操作方式	对焦 手动
		光圈 固定
10	畸变率	1/1.8" -0.3%@y=4.5mm
		1/2" -0.23%@y=4.0mm
		1/3" -0.13%@y=3.0mm
11	滤镜尺寸	M40.5×0.5mm
12	镜头尺寸(宽×长)	68×43mm
13	重量	/
14	工作温度	-40°C~+80°C
15	工作波长	450-1100nm
16	入瞳距离	0mm
17	入瞳直径	23.33mm
18	出瞳距离	-64.05mm
19	出瞳直径	14.23mm
20	光学总长	77.52mm

